

Certikin
international ltd

SWIMMING POOL GAS HEATERS

MB105 • MB155

The first ever British
made swimming pool
and spa gas heater

FEATURES

- Fully CE approved by British Gas in the UK
- UK based technical expertise
- Electronic Ignition guarantees highly reliable performance
- Strong, weatherproof, powder coated casing suitable for indoor or outdoor installation
- Patented highly efficient heat exchanger
- High operational efficiency



Certikin's swimming pool gas heater is the result of many years of designing, engineering and manufacturing all types of residential and commercial pool, space, and hot water heaters.

It's simply the best you can buy.

SWIMMING POOL GAS HEATERS

EconTherm Heat Exchanger

The MB range is equipped with a unique all-copper finned tube heat exchanger, designed for efficient heat transfer. Both header castings are made of cast iron, durable and corrosion resistant.

UniTherm Flow System

The MB155 heater is equipped with the advanced UniTherm Plus Full Flow system which controls both water temperature and flow rate inside the heater thus eliminating condensation, soot and scale buildup.



Longer lasting tough exterior

The MB range's exterior polyester coating is a non-polluting synthetic material that's applied electrostatically in powder form, then melted and fused into a smooth, hard coating in baking ovens. That means no cracking, scratching, peeling or fading. You can count on a long-lasting, lustrous protective finish that lasts years longer than ordinary painted or baked enamel finishes.

Cost and energy efficient

The new range of MB 105/155 heaters from Certikin spare you the costly installation of heat sinks because the alumina silica combustion chamber does not retain heat when the heater shuts off. Energy smart Certikin heaters consistently achieve the highest efficiency ratings.

Simply the best

The Certikin MB105/155P heaters with EconoTherm heat exchangers and UniTherm Plus system last longer and deliver more heat to your pool or spa water, per unit of fuel, than any other heaters you can buy.

With many years of experience in designing, engineering, and manufacturing all types of residential and commercial pool, space, and hot water heaters, Certikin's swimming pool gas heaters are simply the best.

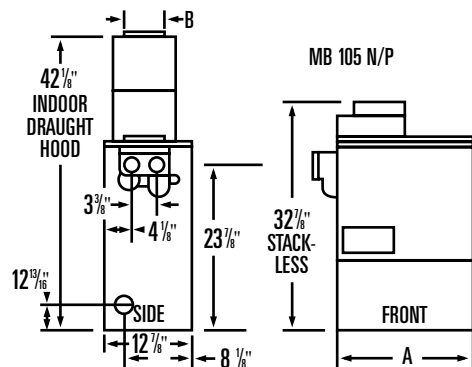
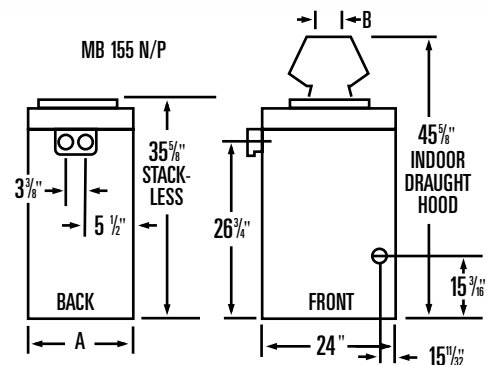

SPECIFICATIONS & DIMENSIONS

MODEL	BTU INPUT	CABINET WIDTH(A)	FLUE DIAMETER	WATER CONNECTIONS
MB105N/P	91.000 26.67 KW	20 1/8" 511 mm	5" 127 mm	1 1/2" 2"
MB155N/P	133.000 38.98 KW	14 5/8" 371 mm	6" 152 mm	1 1/2" 2"

If you should require further technical information please do not hesitate to contact us.

Certikin
international ltd

SWIMMING POOL/SPA GAS HEATERS

• MB055 •

**The first ever British
made swimming pool
and spa gas heater**

FEATURES

- Ideal for smaller pools and spas
- Fully CE approved by British Gas in the UK
- UK based technical expertise
- Electronic Ignition guarantees highly reliable performance
- Strong, weatherproof, powder coated casing suitable for indoor or outdoor installation
- Patented highly efficient heat exchanger
- High operational efficiency
- Natural gas and LPG models available
- 44,000 BTU input (105,000 155,000 265,000 and 405,000 sizes also available)



Certikin's swimming pool gas heater is the result of many years of designing, engineering and manufacturing all types of residential and commercial pool, spa, and hot water heaters.

It's simply the best you can buy.

SWIMMING POOL GAS HEATERS

EconTherm Heat Exchanger

The heater is equipped with a unique all-copper finned tube heat exchanger, designed for efficient heat transfer. The header casting is made of bronze, durable and corrosion resistant.

UniTherm Flow System

The heater is equipped with the advanced Unitherm Plus Full Flow system which controls both water temperature and flow rate inside the heater thus eliminating condensation, soot and scale buildup.

Longer lasting tough exterior

The exterior polyester coating is a non-polluting synthetic material that's applied electrostatically in powder form, then melted and fused into a smooth, hard coating in baking ovens. That means no cracking, scratching, peeling or fading. You can count on a long-lasting, lustrous protective finish that lasts years longer than ordinary painted or baked enamel finishes.

Cost and energy efficient

The new range of MB 055 heaters from Certikin spare you the costly installation of heat sinks because the alumina silica combustion chamber does not retain heat when the heater shuts off. Energy smart Certikin heaters consistently achieve the highest efficiency ratings.

Simply the best

The Certikin heaters with EconoTherm heat exchangers and UniTherm Plus system last longer and deliver more heat to your pool or spa water, per unit of fuel, than any other heaters you can buy.

With many years of experience in designing, engineering, and manufacturing all types of residential and commercial pool, space, and hot water heaters, Certikin's swimming pool gas heaters are simply the best.



SPECIFICATIONS & DIMENSIONS			
MODEL	BTU INPUT	FLUE DIAMETER	WATER CONNECTIONS
MB055N/P	44,000	4"	1 1/2"
	13kW	100 mm	38 mm

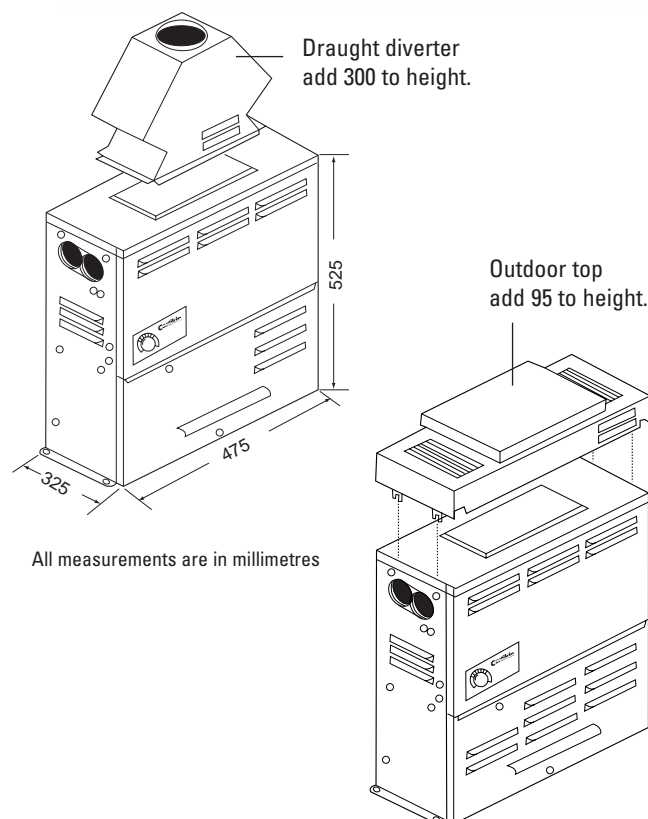

If you should require further technical information please do not hesitate to contact us.

